



Above all else...
GATHER THE DATA



Solutions designed and produced in Italy

WHO IS 4NEXT

4next is a consolidated group of experts that designs and manufactures products for **automation, data collection** and **management** in M2M and IoT applications.

Our product lines include:

1 CONFIGURABLE
DATA LOGGER

2 PROGRAMMABLE
RTU

3 COMMUNICATION
GATEWAY

4 PROTOCOL
CONVERTERS

5 WIRELESS BRIDGES
AND SENSORS

The ideal applications to make the most of the potential of our products are: **metering** (Energy, Water, Gas), **water treatment, renewables, industrial** and **process** control, **measurements** in thermal power plants, agri-food **monitoring, automotive** and vehicle **fleet management**.

Our mission is to conceive, design and develop **cutting-edge technical solutions** in expertise areas and transforming relationships with our customers into real partnerships: strong and trusting relationships that have often led us to jointly develop ad-hoc products and systems. This has been possible thanks to our decades of experience in the field of electronics, information technology and automation which allowed us to conceive the best solution according to the available budget and the desired time to market. All this passes through the culture of innovation that has always been rooted in our company.

CEO & FOUNDER

Gino Cecchetti

Data Loggers

DATA LOGGERS OF THE “EASY” FAMILY INTERFACE WITH ALL **MODBUS RTU AND TCP** DEVICES AND SEND DATA TO THE CLOUD USING STANDARD MQTT, HTTP, FTP AND OPC UA PROTOCOLS.



SAVING DATA TO SD MEMORY



AUTOMATIC EXPORT TO CSV/JSON



IMPORT TO EXCEL FROM CSV FILE



SENDING DATA TO THE CLOUD VIA MQTT, HTTP REST



IMPORT/EXPORT LIBRARIES



REAL-TIME RECORDING

Ideal Data Logger Applications :

- METERING
- RENEWABLES
- INDUSTRIAL AND PROCESS CONTROL
- WATER TREATMENT
- MEASUREMENTS IN THERMAL PLANTS
- AGRI-FOOD MONITORING

EasyLog XL / XL-A



Scan the QR CODE TO ACCESS DATA SHEET

EasyNET



Scan the QR CODE TO ACCESS DATA SHEET

DLG



Scan the QR CODE TO ACCESS DATA SHEET

EASYSense



Scan the QR CODE TO ACCESS DATA SHEET

EasyLog XL

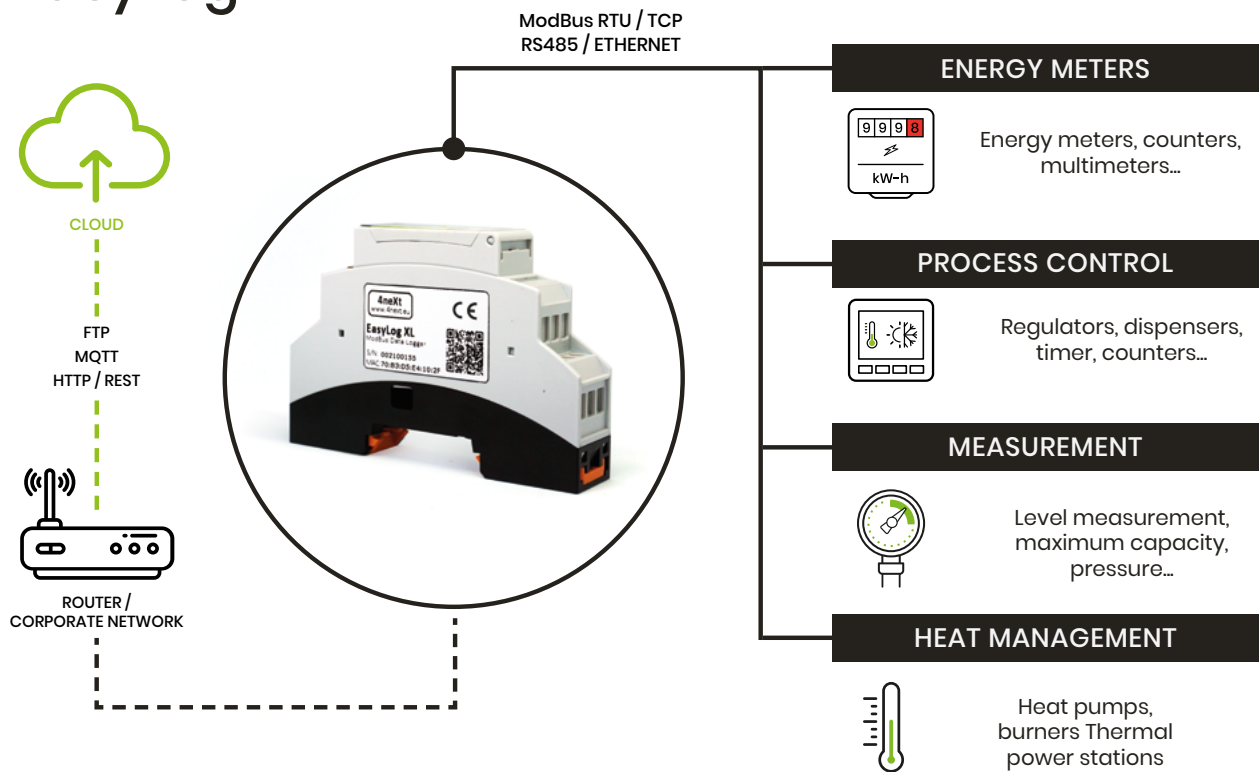

CONNECTION SCHEMES

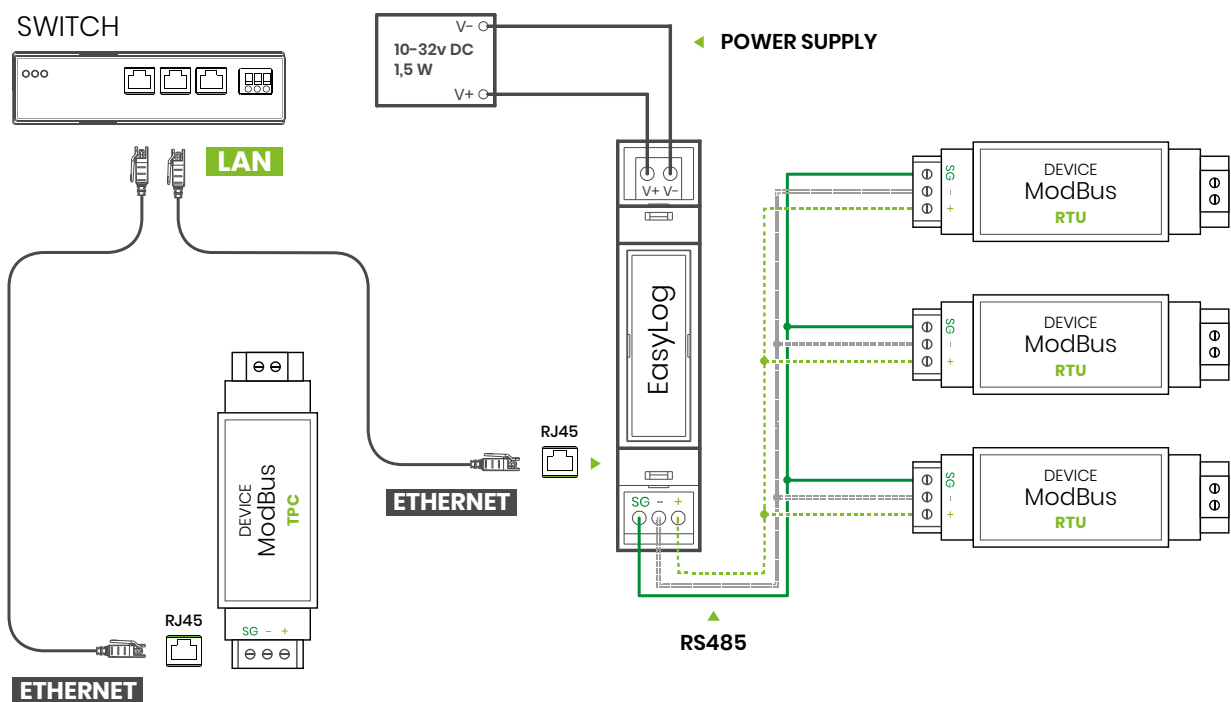

EasyNET

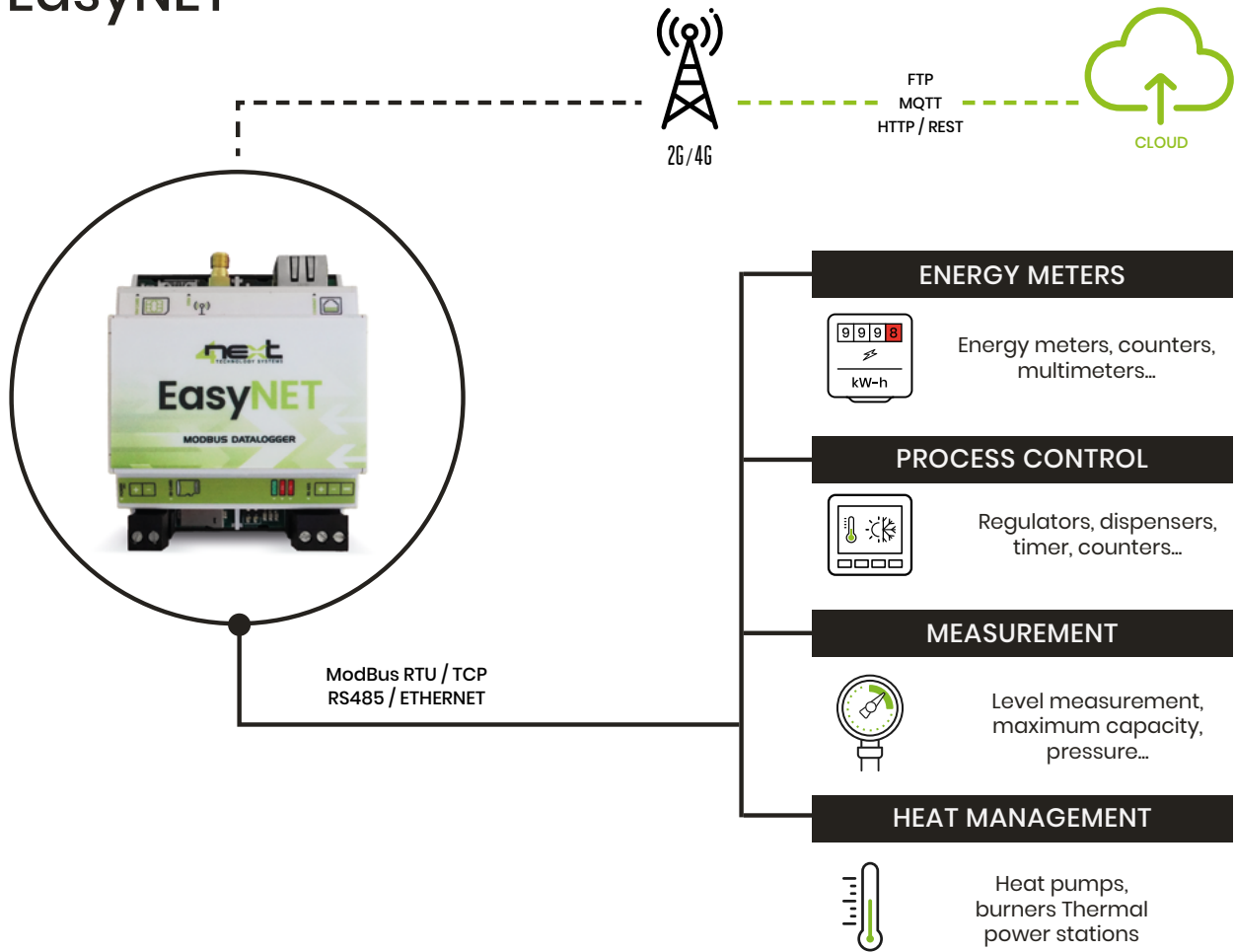

CONNECTION SCHEMES

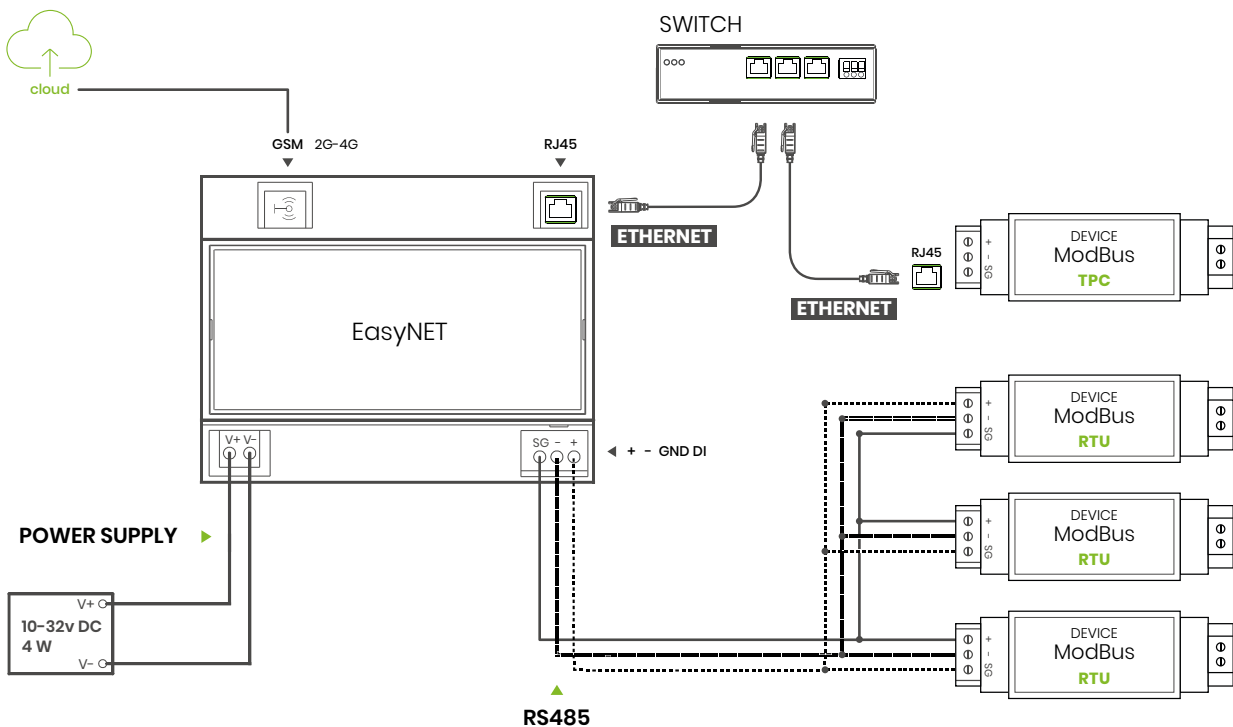

Comparative technical features

	EasyLog XL/XL-A	EasyLog UA	EasyNET
Power supply	10-32 v DC/AC	10-32 v DC	10-32 v DC
Ethernet port	10-100 Mb/s	10-100 Mb/s	10-100 Mb/s
RS485 port	1200-115200 bps	1200-115200 bps	1200-115200 bps
Signaling LEDs	✓	✓	✓
Size	90x17x60 mm	90x17x60 mm	90x70x60 mm
Operating temperature	-20°C + 60°C	-20°C + 60°C	-20°C + 60°C
DIN rail support	1 module	1 module	4 modules
Average absorption	< 1,5 W	< 1,5 W	< 4 W
CE certification	✓	✓	✓
Managed variables	384	384	384
ModBus writing	✓	✗	✓
MQTT	✓	✓	✓
FTP	✓	✓	✓
Modem 2G/4G / NB-IoT	✗	✗	✓
OPC UA	✗	✓	✗
Pulse counter	✗	✗	✓

SERIE DLG

THE **DLG** DATA LOGGER ALLOWS INTERFACING WITH ALL DEVICES MODBUS RTU AND TCP IN A SIMPLE WAY WITHOUT KNOWING HOW TO PROGRAM.

	DLG-M2	DLG-A4	DLG-D16	
Configurable analog inputs (0-10V, 4-20mA, NTC, PTC)	2	4	⊗	
Analog outputs (0-10V e 4-20mA)	⊗	4	⊗	
Digital Inputs / Outputs	2	⊗	TO CHOOSE BETWEEN:	
			INPUTS	OUTPUTS
			16	0
			12	4
			8	8
4	12			
0	16			
Webserver for configuration	integrated	integrated	integrated	
NFC interface	✓	✓	✓	
WiFi/Bluetooth modules	optional	optional	optional	
Removable clamps	✓	✓	✓	
Ethernet and RS485 serial port	✓	✓	✓	
Micro SD slot for cards up to 64GB	✓	✓	✓	
RTC Clock	✓	✓	✓	

CONNECTION SCHEMES

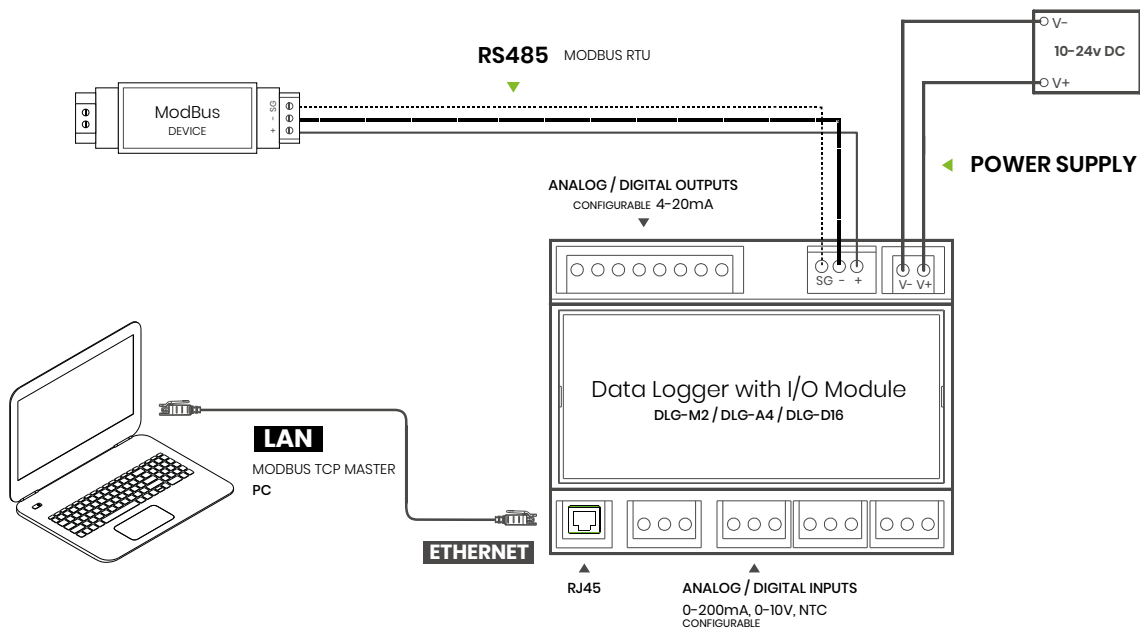

EasySense

EASYSENSE IS A BATTERY POWERED IOT GATEWAY WITH I/O FOR THE CONNECTION TO A WIDE RANGE OF SENSORS.

EasySense is designed to operating in particularly burdensome environments where power is not always available and where it is necessary to **acquire data from different types of sensors**. EasySense is able to communicate even with sensors and **RTU ModBus** devices. Thanks to the integrated WiFi / Bluetooth module and the NFC, the **configuration is easy and fast**.

- ✓ 2G AND 4G MODEM (LTE CAT-M1 / NB-IoT)
- ✓ HIGH-PRECISION GPS
- ✓ WIFI & BLUETOOTH COMMUNICATION
- ✓ RUGGED AND WATERPROOF IP67 CASE
- ✓ BATTERY POWERED OR POWER SUPPLY FROM 10-32 v DC
- ✓ EXTENDED TEMPERATURE RANGE -20 ÷ +65 °C
- ✓ 2 ANALOGUE INPUTS CONFIGURABLE PER INPUT 0-5V, 0-10V, 4-20mA AND Pt100
- ✓ 3 DIGITAL INPUTS
- ✓ 2 DIGITAL OUTPUTS (RELÈ)
- ✓ RS485
- ✓ CLOCK FUNCTION (RTC)
- ✓ NFC
- ✓ 3-AXIS ACCELEROMETER

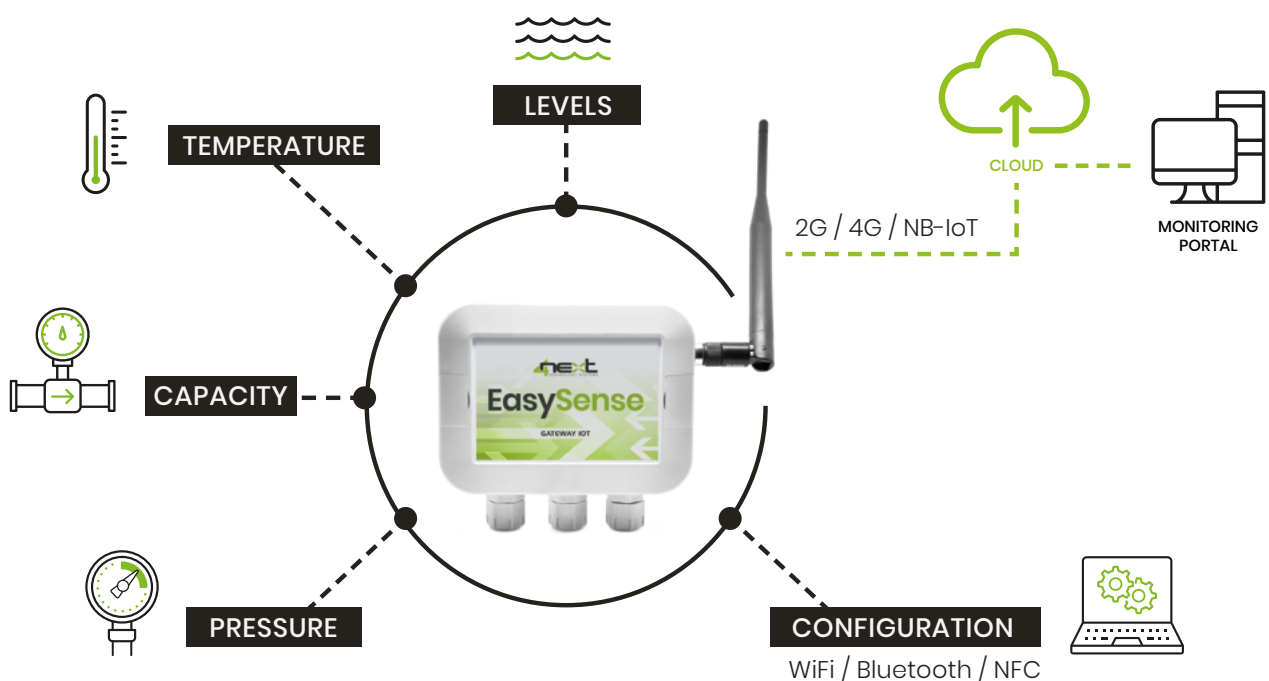

CONNECTION SCHEMES

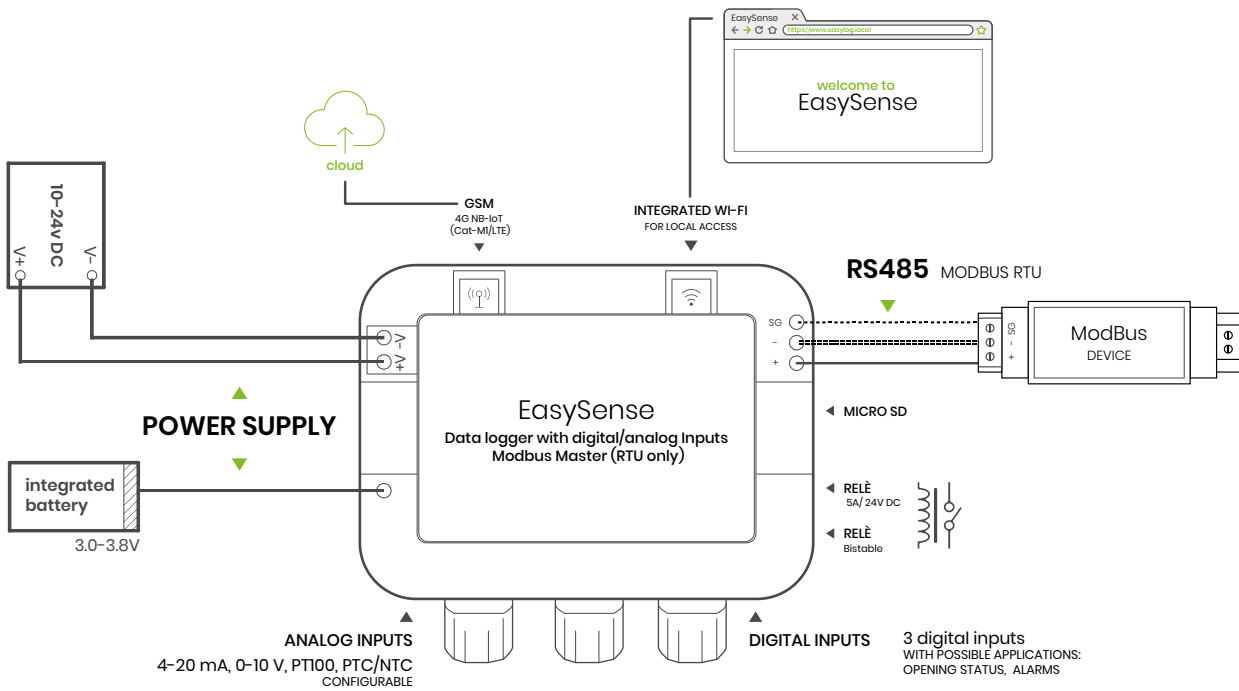

ModBus Bridges

MODBUS BRIDGES ALLOW MODBUS RTU DEVICES TO COMMUNICATE WITH IP DEVICES (PC, PLC, ELECTRONIC BOARDS).

 **SPECIALLY DESIGNED FOR INDUSTRIAL ENVIRONMENTS**

 **EXTENDED RANGE POWER SUPPLY 10-32 v DC**

 **PROTECTION ON THE SERIAL PORT THANKS TO GALVANIC ISOLATION**

 **EASILY PROGRAMMABLE VIA INTEGRATED WEB INTERFACE AND A FREE APP**

They are the ideal solution for any type of application where serial devices need to communicate with the most modern automated systems.

VERSIONS: **MDB-E** (Ethernet), **MDB-W** (WiFi) and **NetLink** (Radio)

MDB-E



Scan the QR CODE
TO ACCESS DATA SHEET

MDB-E IS AN ETHERNET - SERIAL RS485 COMMUNICATION BRIDGE WITH NFC INTERFACE.

MDB-W



Scan the QR CODE
TO ACCESS DATA SHEET

MDB-W IS A WIFI - SERIAL RS232/RS485 COMMUNICATION BRIDGE WITH WIFI INTERFACE.

NETLINK



Scan the QR CODE
TO ACCESS DATA SHEET

NETLINK IS A RADIO COMMUNICATION BRIDGE BETWEEN DEVICES WITH SERIAL OR ETHERNET PORT WITH NFC INTERFACE.

MDB-E

ModBus Bridge with easily programmable NFC interface: no additional software is required for configuration.

CONNECTION SCHEME

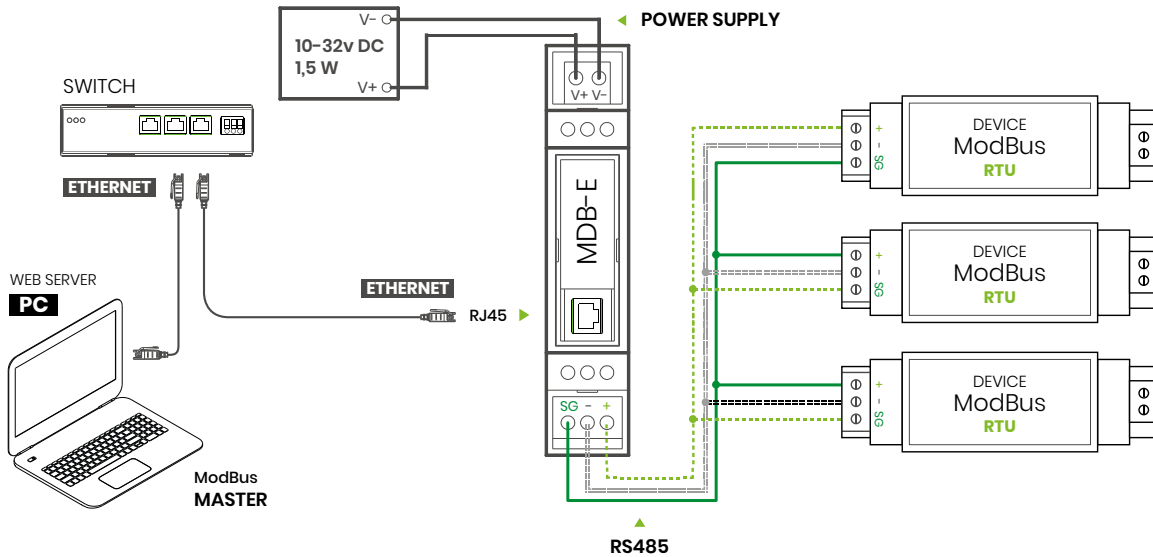

MDB-W

ModBus Bridge with WiFi interface, easy to program and configure thanks to the integrated web server.

CONNECTION SCHEME

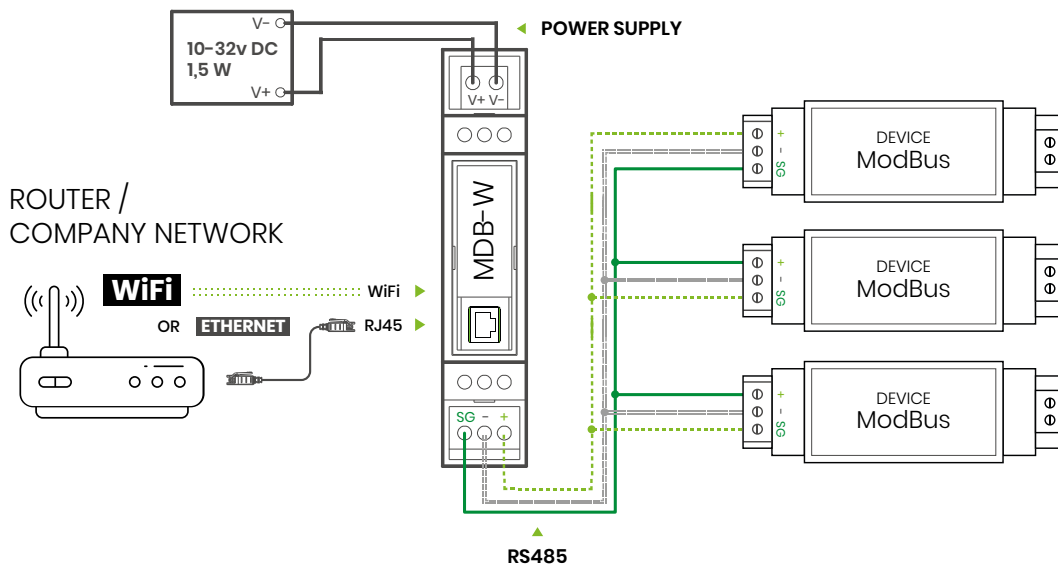

MDB-W

MDB-W IS IDEAL AS A CONVERTER FOR MODBUS PROTOCOL.

It is **available in 3 versions:**

WiFi - RS485, WiFi - RS232 & RS232 - RS485

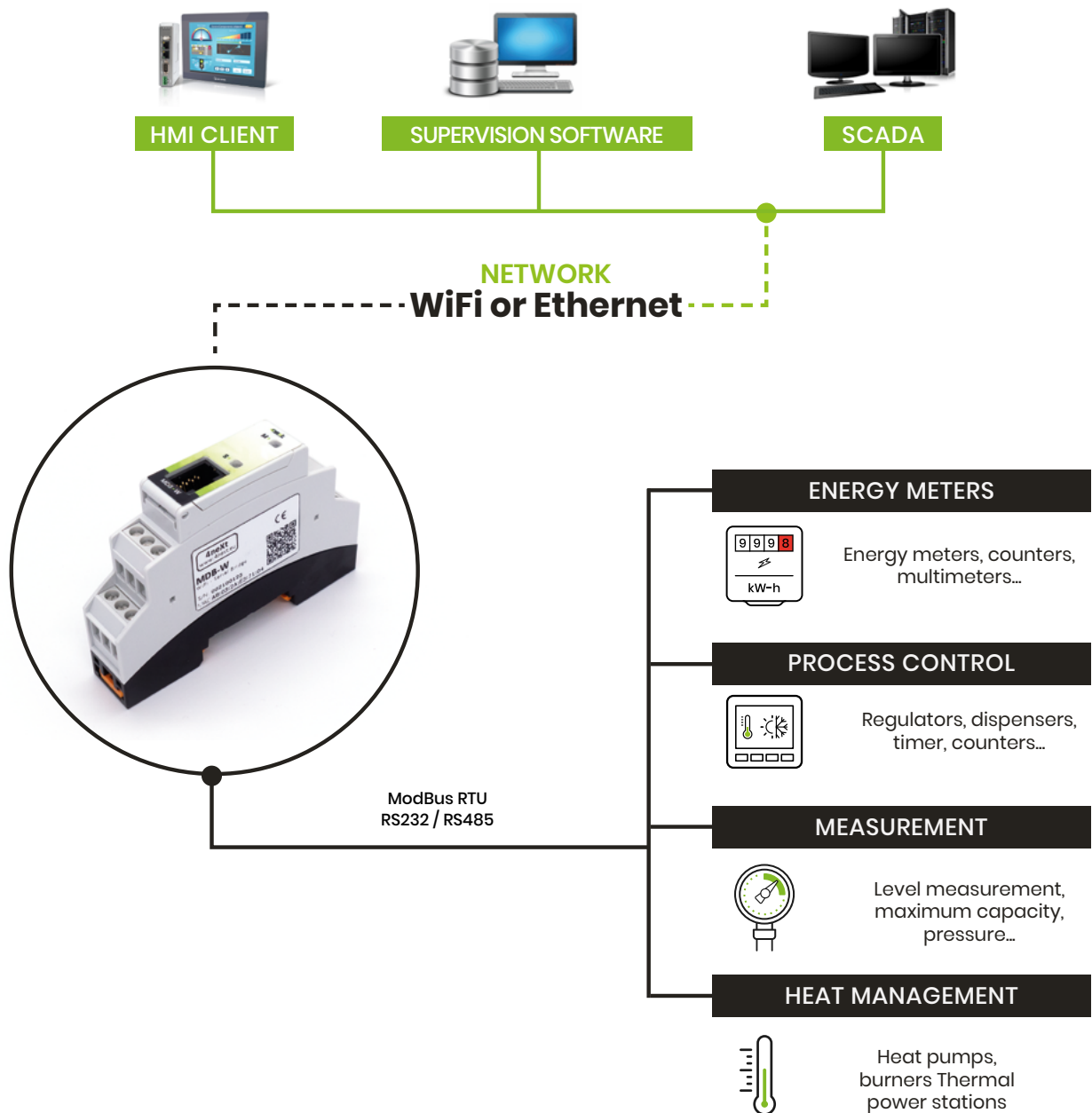

NetLink

NetLink is a Radio Bridge that allows devices equipped with a serial and/or Ethernet port to communicate with each other wirelessly up to 800m.

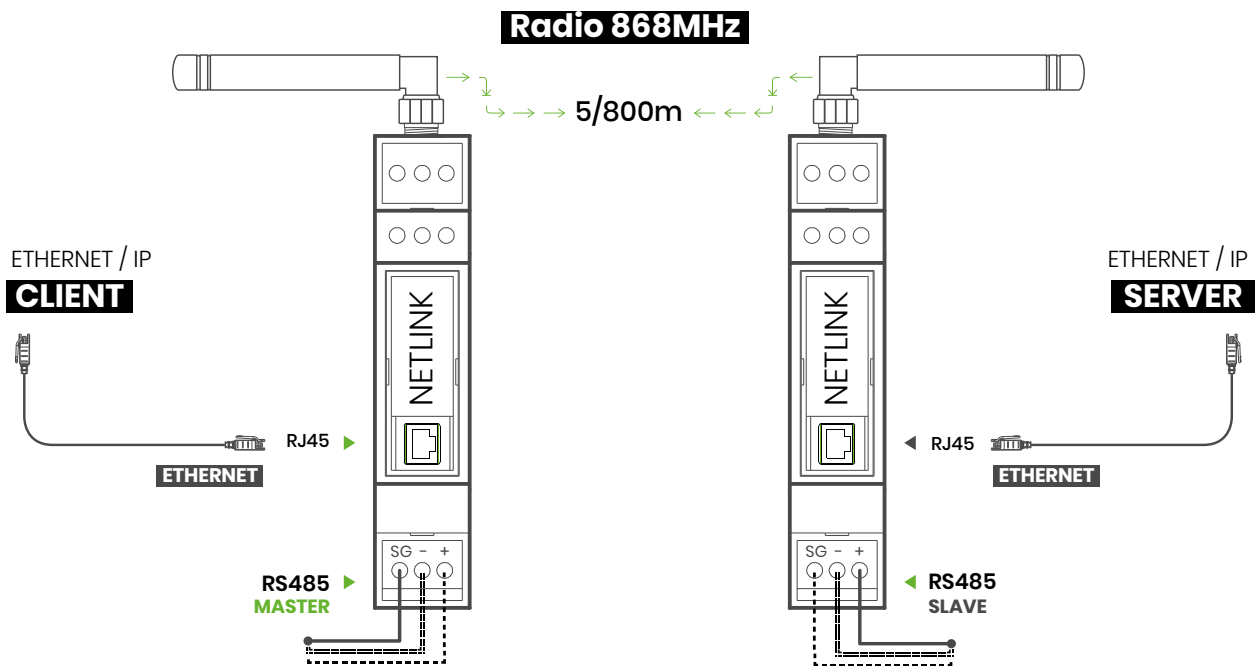

Thanks to its multiple interfaces, **NetLink** enables the following functions:

- ✓ TRANSPARENT CONNECTION / CABLE REPLACEMENT
- ✓ RADIO BRIDGE BETWEEN SERIAL AND SERIAL (RS485)
- ✓ RADIO BRIDGE BETWEEN SERIAL AND ETHERNET (AND VICE VERSA)
- ✓ RADIO BRIDGE BETWEEN ETHERNET AND ETHERNET

These the most common applications:

- ✓ Communication between Master and ModBus slaves
- ✓ Remotely wireless data transmission (5/800m)
- ✓ Ethernet/serial protocol conversion
- ✓ RS485 protocol conversion

Point-to-point mode is the classic cable replacement, but NetLink allows connection and channel conversion from RS485 and Ethernet.

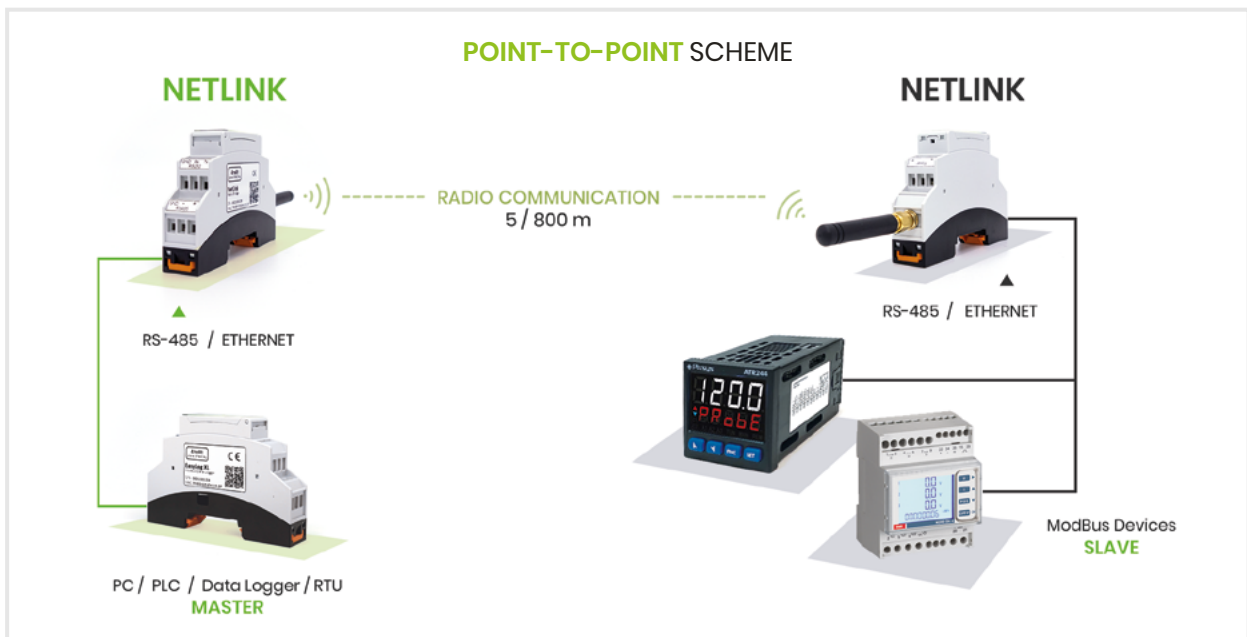

Point-to-multipoint mode allows the data file to be collected from a complex network in a very simple way

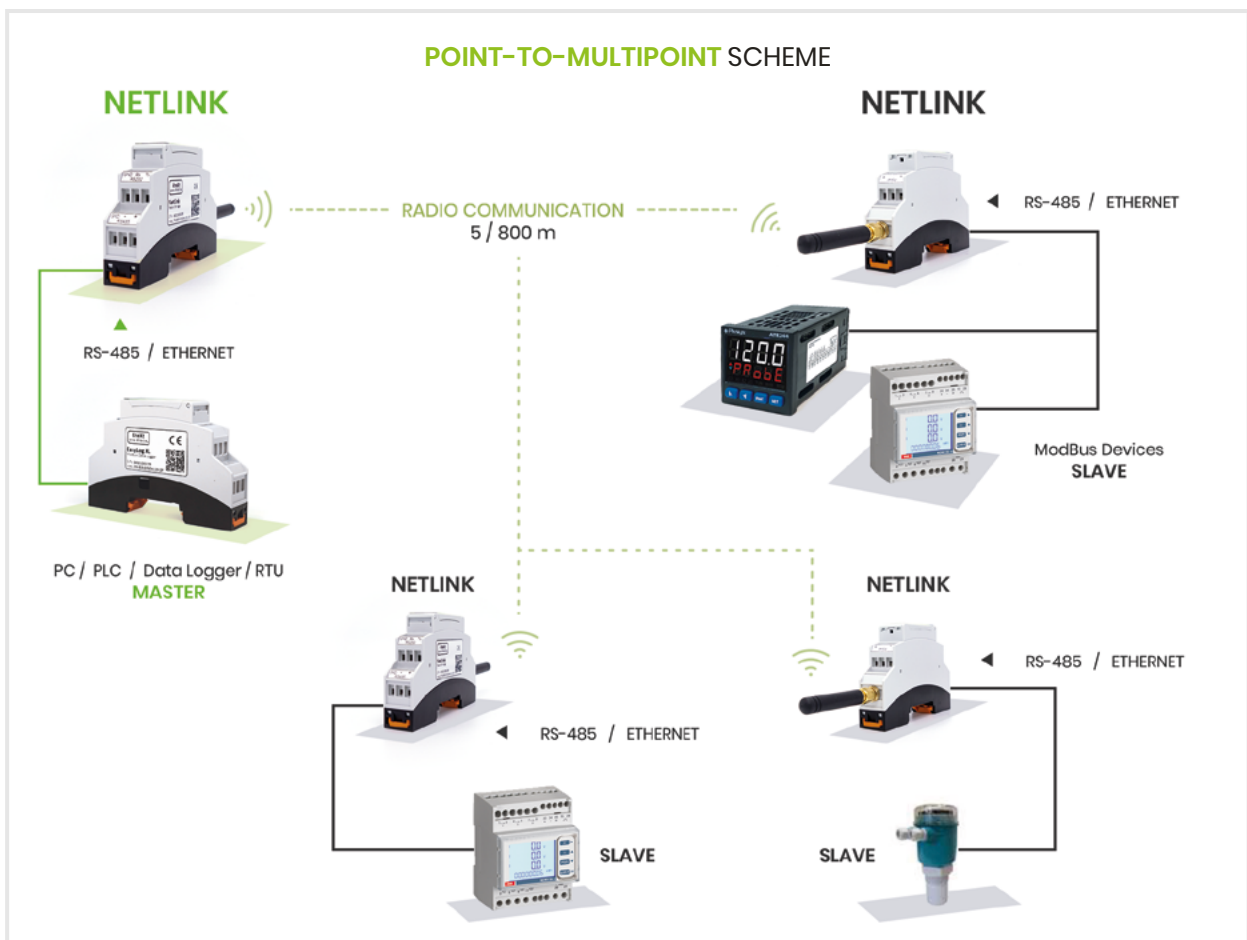

Comparative technical features

GENERAL	MDB-E	MDB-W	NETLINK
RS485 optoisolated	✓	✓	✓
RS232 optoisolated (Rx, Tx, GND)	✓	✓	✗
TCP, UDP or ModBus TCP	✓	✓	✓
Serial communication speed up to 115.200 bit/s	✓	✓	✓
WiFi 802.11 b/g/n, WPA, WPA2, WPS	✗	✓	✗
868 MHz radio module	✗	✗	✓
Programming via NFC	✓	✗	✓
Power supply 10-32 v DC	✓	✓	✓
MECHANICAL	MDB-E	MDB-W	NETLINK
IP41 plastic case for DIN rail	✓	✓	✓
Size: 18 x 90 x 60 mm (1 module DIN)	✓	✓	✓
SOFTWARE	MDB-E	MDB-W	NETLINK
Conversion ModBus TCP/ RTU on RS485	✓	✓	✓
Conversion ModBus TCP/ RTU on RS232	optional	✓	optional
Bidirectional protocol conversions on all channels	✓	✓	✓
Easy and fast configuration via APP	✓	✓	✓
ENVIRONMENTAL	MDB-E	MDB-W	NETLINK
Operating temperature: -20°C ÷ 60°C	✓	✓	✓
Relative humidity: from 0 to 80% without condensation	✓	✓	✓
Storage temperature: -40° ÷ + 60°	✓	✓	✓

ModBus RTU and TCP I/O modules

I/O ACQUISITION MODULES, EQUIPPED WITH CAN BUS AND MODBUS, ARE SPECIFICALLY DESIGNED FOR INDUSTRIAL APPLICATIONS.

I/O module features:



SPECIALLY DESIGNED FOR INDUSTRIAL ENVIRONMENTS



RUGGED LAYOUT AND EASY INSTALLATION



GALVANICALLY ISOLATED TO PROTECT THE ENTIRE CIRCUIT



EASY CONFIGURATION VIA NFC WEB INTERFACE: NOT TIME-CONSUMING PREPARATION REQUIRED

Thanks to inputs configurability, each module is versatile and can be used for different types of probes. ModBus and CANbus I/O acquisition modules are equipped with a DIN-rail housing and are easy to install.

NXT-M2



Scan the QRCODE TO ACCESS DATA SHEET

NXT-A4



Scan the QRCODE TO ACCESS DATA SHEET

NXT-D4



Scan the QRCODE TO ACCESS DATA SHEET

NXT-D16



Scan the QRCODE TO ACCESS DATA SHEET

NXT SERIES

NXT IS AN I/O MODULE COMPATIBLE WITH MODBUS RTU AND TCP PROTOCOLS.

This ModBus remote I/O acquisition module is available in four VERSIONS: **NXT-M2**, **NXT-A4**, **NXT-D16** and **NXT-D4**

	NXT-M2	NXT-A4	NXT-D16	NXT-D4
Configurable analog inputs (0-10V, 4-20mA, Pt100, Pt1000, NTC, PTC, Thermocouples)	2	4	⊗	⊗
Digital inputs + counters	4	⊗	16	4
Analog output (0-10V e 4-20mA)	⊗	4	⊗	⊗
Digital outputs	2	⊗	16	4
NFC interface for the configuration	✓	✓	✓	✓
868MHz radio module	optional	optional	optional	⊗
WiFi interface	optional	optional	optional	⊗
NXT power supply from 12-48 vDC	✓	✓	✓	✓

CONNECTION SCHEMES

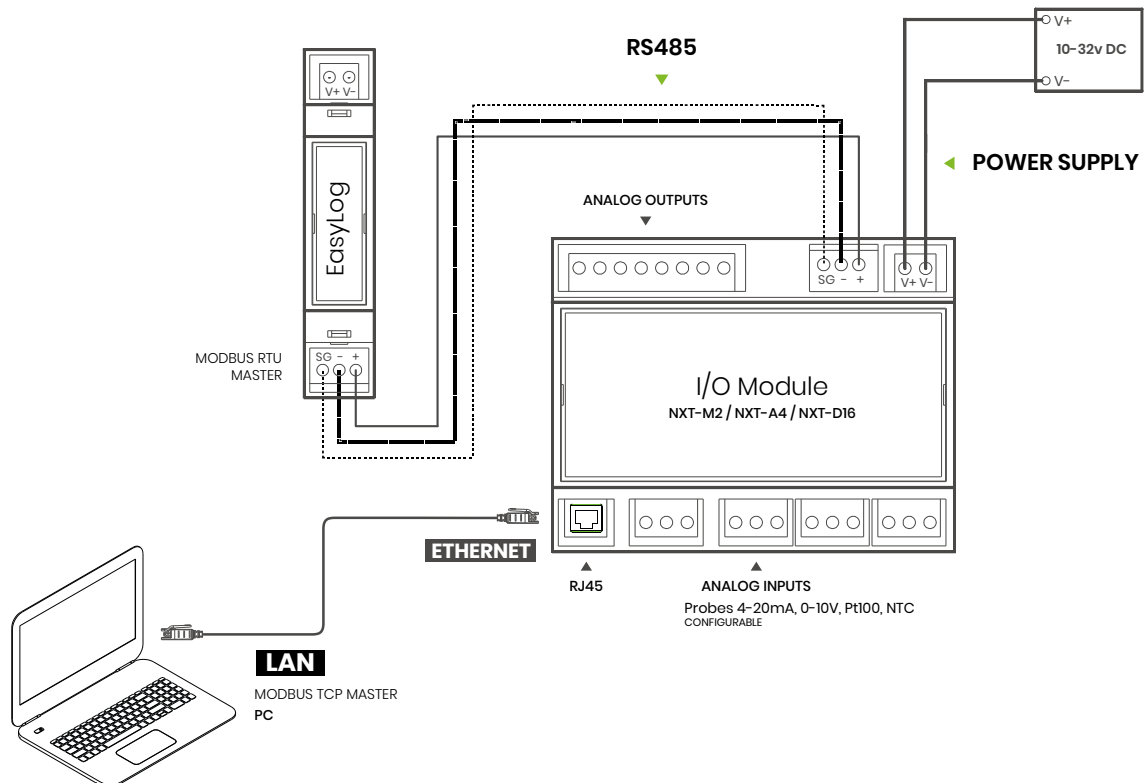

MCM modules I/O

MCM I/O ACQUISITION MODULES, EQUIPPED WITH RS485 SERIAL AND CANOPEN, ARE IDEAL FOR INTERFACING TO ANALOGUE DIGITAL SENSORS AND FOR IMPLEMENTING/CONTROLLING OUTPUTS.

Thanks to inputs configurability, each module is versatile and can be used for different types of probes. The ModBus RTU (RS485) and CANbus expansion modules are all equipped with a DIN rail housing and removable terminals for easy installation and wiring.

MCM I/O modules features:



**RUGGED AND EASY
INSTALLATION LAYOUT**



**SPECIALLY DESIGNED FOR
INDUSTRIAL ENVIRONMENTS**



**GALVANICALLY ISOLATED TO
PROTECT THE ENTIRE CIRCUIT**



**QUICK AND EASY
CONFIGURATION**



**CONVENIENTLY CONFIGURABLE AND
MANAGEABLE ALSO THROUGH "aMBition"**

MCM SERIES



Scan the QR CODE
TO ACCESS DATA SHEET

MCM SERIES

I/O MCM ACQUISITION MODULES ARE EQUIPPED WITH RS485 SERIAL AND CANOPEN.

MCM modules are available in six VERSIONS: MCM-16DO, MCM-16DI, MCM-88D, MCM-88R, MCM-42A and MCM-1642

Low voltage DC operation is provided for the MCM-16DO, MCM-16DI, MCM-88D, MCM-1642 models, while models with relay outputs or analogue inputs/outputs MCM-88R, MCM-42A are provided for low voltage DC and alternating voltage.

TECHNICAL FEATURES

	MCM-16DO	MCM-16DI	MCM-88D	MCM-88R	MCM-42A	MCM-1642
Digital Inputs	-	16	8	8	-	16
Digital Outputs	16	-	8	-	-	16
Analog Inputs	-	2	-	2	4	4
Analog Outputs	-	-	-	-	2	2
Encoder inputs/counter	-	3	3	3	-	4
Relay	-	-	-	8	-	-

IoT gateway

IOT GATEWAYS NOT ONLY ENABLE COMMUNICATION BETWEEN DEVICES OR WITH THE CLOUD, BUT ALSO ALLOW DATA PROCESSING.

IDEAL FOR INDUSTRY 4.0

owa344



Scan the QR CODE
TO ACCESS DATA SHEET

owa4X



Scan the QR CODE
TO ACCESS DATA SHEET

owa450



Scan the QR CODE
TO ACCESS DATA SHEET

owa5X



Scan the QR CODE
TO ACCESS DATA SHEET

APPLICATION EXAMPLE

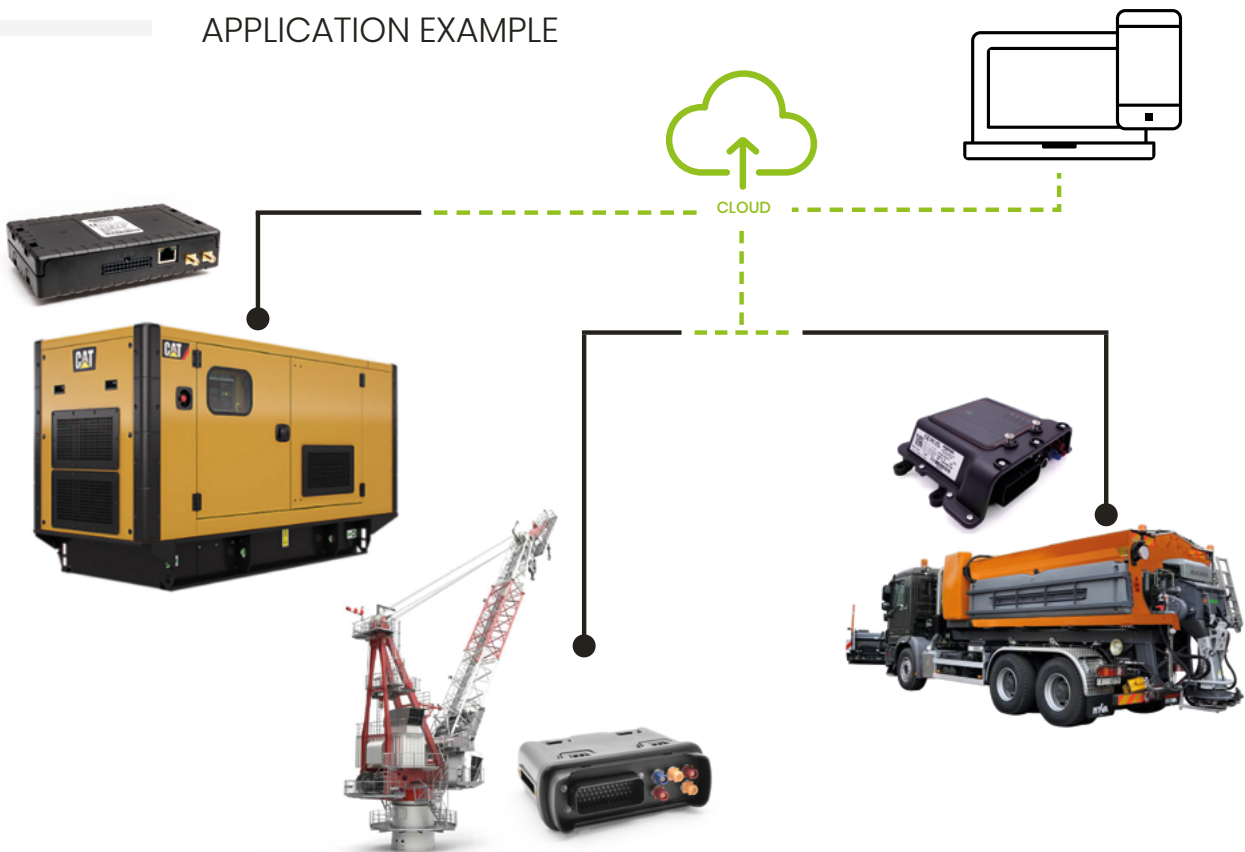

Owa344

OWA344 IS A POWERFUL OPEN EMBEDDED LINUX IOT PLATFORM FOR DEVELOPING TELEMETRY AND TELEMATICS APPLICATIONS WITH A WIDE RANGE OF CONNECTIVITY OPTIONS.

Owa344 is an embedded Linux IoT platform that allows you to fully control remote data collection and processing.

It is the ideal gateway for controlling and monitoring industrial machines and vehicles. A robust family of open, flexible, and powerful wireless embedded computers that offers fully wireless functionality for remote management and monitoring.

By combining the best set of technologies and features available from a wide range of options, you can develop cutting-edge telemetry and telematics applications.

Owa4x

OWA4X IS AN OPEN AND POWERFUL LINUX IOT IP67 PROGRAMMABLE GATEWAY.

It allows you to easily create your own application, collect, select and process meaningful data from the field and to send remotely only the salient information. Equipped with numerous wired and wireless interfaces, it provides with complete supervision capabilities for remote management and monitoring.

The **IP67** enclosure enable the use of owa4X in hostile environments: **extreme temperatures**, weather or potentially **harmful dust**.

Owa450

FAMILY OF POWERFUL LINUX IOT GATEWAYS FOR COLLECTING AND PROCESSING DATA FROM SENSORS, DEVICES AND PERIPHERALS.

Its excellent price-performance ratio makes it perfect for monitoring and controlling remote peripherals, sending only the relevant information to the cloud or to your control centre.

ITxPT certification makes it ideal for all telemetry and control applications in transport vehicles.

Owa5x

OWA5X INCORPORATES THE BEST ELECTRONIC TECHNOLOGIES FROM PROCESSOR TO CONNECTIVITY SYSTEMS.

A true technological jewel that allows the development of all Edge applications advanced gateways, **Artificial Intelligence**, encryption and **Cybersecurity** thanks to its 1.6MHz quad core **i.MX8** processor.

Comparative technical features

	owa344	owa4X
Power supply	9-48 v DC	
Consumption	50,50 mA (RUN, ETH0, ETH1) 68,10 mA (RUN, GSM, ETH0, ETH1) 9,53 mA (Standby)	50mA (RUN) 9mA (Standby)
Processor	ARM7 Cortex 32bit 792MHz	ARM Cortex A8 32bit 800MHz
Linux	6.6.15 Kernel	4.4.19
O.S.	Yocto / Linux	Debian 10
IP Protection	IP40	IP67
RAM	512 MB	512 MB
Flash memory	512 NAND + 8GB eMMC	1 GB+ 512 MB DDR3
Battery	Rechargeable/Lithium-ion	
Receiver	GPS / GLONASS / QZSS / BeiDou / Galileo, 72 channels, continuous	
LTE	✓	✓
GSM / GPRS	✓	✓
CAN	Up to 4 CAN bus	
USB	✓	✓
Ethernet	✓	✓
WiFi	✗	✓
Bluetooth	✗	✓
RS232	2	3
RS485	2	1
Audio Codec	✗	✓
SD CARD	✗	✗
SIM	✓	✓
Digital Inputs	9	10 (configurable)
Analog Inputs	4	4
Digital Outputs	2-6	10 (configurable)

	owa450	owa5X
Power supply	9-48 v DC	
Consumption	73 mA (RUN+GSM+GPS) 47 mA (RUN) 9.88 Ma (Standby)	92.60 mA (RUN+GSM+GPS) 51.95 mA (RUN) 12.36 Ma (Standby)
Processor	ARM Cortex A8 32bit 800MHz	i.MX8 M Plus Quad A53 64 bit a 1,6 GHz
Linux	Kernell 4.4.19	Kernell 5.4.70
O.S.	Debian 10	Debian 11
IP Protection	IP40	IP67
RAM	512 MB	2 GB
Flash memory	1 GB+32 GB con USB	1GB NAND Flash SLC + 8 GB EMMC Flash + 2 GB LPDDR4
Battery	Rechargeable/Lithium-ion	
Receiver	GPS / GLONASS / QZSS / BeiDou / Galileo, 72 channels, continuous	
LTE	☑	☑
GSM / GPRS	☑	☑
CAN	Up to 4 CAN bus	
USB	☑	☑
Ethernet	☑	☑
WiFi	☑	☑
Bluetooth	☑	☑
RS232	3	2
RS485	2	optional
Audio Codec	☑	⊗
SD CARD	☑	☑
SIM	☑	☑
Digital Inputs	10 (configurable) + 3 extra optional	12 (configurable)
Analog Inputs	4	4
Digital Outputs	10 (configurable)	12 (configurable)

Atvise®

ATVISE IS SCADA SOFTWARE IN PURE WEB TECHNOLOGY.

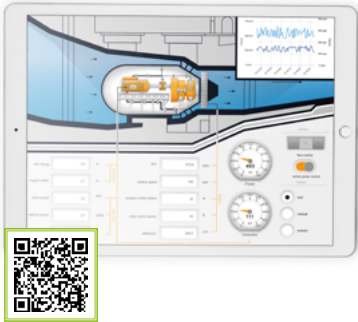

Scan the QR CODE
AND ACCESS THE PRODUCT DATA SHEET

Atvise® is a powerful **HMI and SCADA visualization software** based entirely on the latest Internet technologies. Using open interface standards such as HTML5 and vector graphics (SVG) it allows access to information from any PC, Mac, Mobile device without additional plug-ins. Valid **industrial standards** (OPC UA) allow development time to be minimised, especially the parameterisation

of plants and processes. Atvise® Scada independently supports all typical SCADA functions such as alarms, historization, trends, user management, multi-language, etc. Thanks to its **flexibility**, it is generally applicable to all industries, with its main segments in infrastructure, building automation, power generation, production plants and mechanical engineering.



Karadet Web Portal

THE IOT PLATFORM FOR DATA MONITORING AND ANALYSIS.

TRANSFORM THE MANAGEMENT OF YOUR DEVICES WITH A SCALABLE AND SECURE PLATFORM.



Karadet is a cloud-based IoT platform designed to collect, monitor, and analyze data from plants and collected via 4neXt IoT devices.

Thanks to its intuitive interface and advanced features, it allows you to optimize processes, reduce costs, and make decisions based on reliable data in real time.

MAIN FEATURES:

- ✓ **Real-time data collection** – Data acquisition from sensors and IoT devices.
- ✓ **Dashboard** – Data visualization and analysis with interactive graphs and detailed reports.
- ✓ **Alarms and notifications** – Automatic email alerts in case of anomalies or threshold exceedances with fully customizable rules.
- ✓ **Remote control** – Remote device management via PC, tablet, or smartphone.
- ✓ **Full compatibility** – Support for standard IoT protocols (MQTT, Modbus).
- ✓ **Advanced security** – Data protection with encryption and restricted access.
- ✓ **Plug & Play** – Fully plug & play with 4neXt data loggers (EasyLogXL, EasyNET, and EasySense)

APPLICATIONS

INDUSTRY 4.0

Monitoring and optimization of industrial production

SMART AGRICULTURE

Environmental control for greenhouses and smart irrigation.

ENERGY MANAGEMENT

Analysis of energy consumption to reduce waste and costs.

SMART BUILDING

Building automation for more efficient management.

LOGISTICS AND TRANSPORT

Real-time fleet monitoring and asset management.



4next
TECHNOLOGY SYSTEMS



Registered office

Via L. da Vinci, 15/4
30030 Vigonovo (VE)
Italy



Contacts

Tel: + 39 049 09 81 450
Email: info@4next.eu
Web: www.4next.eu



Company data

4neXt S.r.l.
VAT n: IT 04491980274

4next
TECHNOLOGY SYSTEMS